



Differential pressure transmitters with high accuracy and long-term stability

The following options can be specified for the testo 6351:

AXX	Measuring range
BXX	Analog display/supply
CXX	Display / menu language
DXX	Cable input
EXX	Ethernet
FXX	Differential pressure/flow velocity unit (pre-set)
HXX	Relay
KXX	Instruction manual language

AXX Measuring range

A02	0 to 50 Pa
A03	0 to 100 Pa
A04	0 to 500 Pa
A05	0 to 10 hPa
A07	0 to 50 hPa
A08	0 to 100 hPa
A09	0 to 500 hPa
A10	0 to 1000 hPa
A11	0 to 2000 hPa
A22	-50 to 50 Pa
A23	-100 to 100 Pa
A24	-500 to 500 Pa
A25	-10 to 10 hPa
A27	-50 to 50 hPa
A28	-100 to 100 hPa
A29	-500 to 500 hPa
A30	-1000 to 1000 hPa
A31	-2000 to 2000 hPa

BXX Analog display/supply

B02	0 to 1 V (4-wire, 24 VAC/DC)
B03	0 to 5 V (4-wire, 24 VAC/DC)
B04	0 to 10 V (4-wire, 24 VAC/DC)
B05	0 to 20 mA (4-wire, 24 VAC/DC)
B06	4 to 20 mA (4-wire, 24 VAC/DC)

CXX Display / menu language

C00	without display
C02	with display/English
C03	with display/German
C04	with display/French
C05	with display/Spanish
C06	with display/Italian
C07	with display/Japanese
C08	with display/Swedish

DXX Cable input

D01	Cable input M16 (relay: M20)
D02	Cable entry NPT 1/2"
D03	Cable contact via M-plug connection for signal and supply

EXX Ethernet

E00	without Ethernet module
E01	with Ethernet module

FXX Differential pressure/flow velocity unit (pre-set)

F01	Pa / min / max
F02	hPa / min / max
F03	kPa / min / max
F04	mbar / min / max
F05	bar / min / max
F06	mmH ₂ O / min / max
F07	mmH ₂ O / min / max
F08	inch HG / min / max
F09	kg/cm ² / min / max
F10	PSI / min / max
F11	m/s / min / max
F12	ft/min / min / max
F13	m ³ /h / min / max
F14	l/min / min / max
F15	Nm ³ /h / min / max
F16	Nl/min / min / max

Scaling: 50% of measuring range final value; freely selectable within measuring range

HXX Relay

H00	without relay
H01	4 relay outputs, limit value monitoring
H02	4 relay outputs, channel 1 limit values and collective alarm

KXX Instruction manual language

K01	German/English instruction manual
K02	French/English instruction manual
K03	Spanish/English instruction manual
K04	Italian/English instruction manual
K05	Dutch/English instruction manual
K06	Japanese/English instruction manual
K07	Chinese/English instruction manual
K08	Swedish/English instruction manual

Example:

Order code for transmitter testo 6351 with the following options:

- Measuring range 0 to 100 Pa
- Analog output / supply 0 to 5 V (4-wire, 24 VAC/DC)
- with display/English
- Cable entry NPT 1/2"
- with Ethernet module
- Differential pressure mbar / min / max
- 4 relay outputs, limit value monitoring
- Instruction manual language German/English

0555 6351 A03 B03 C02 D02 E01 F04 H01 K01

Differential pressure transmitters with high accuracy and long-term stability

Technical drawings

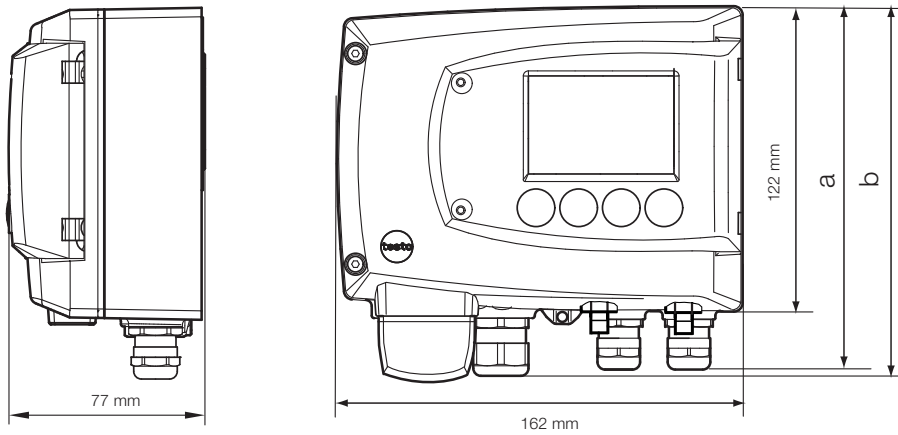

Connection plan

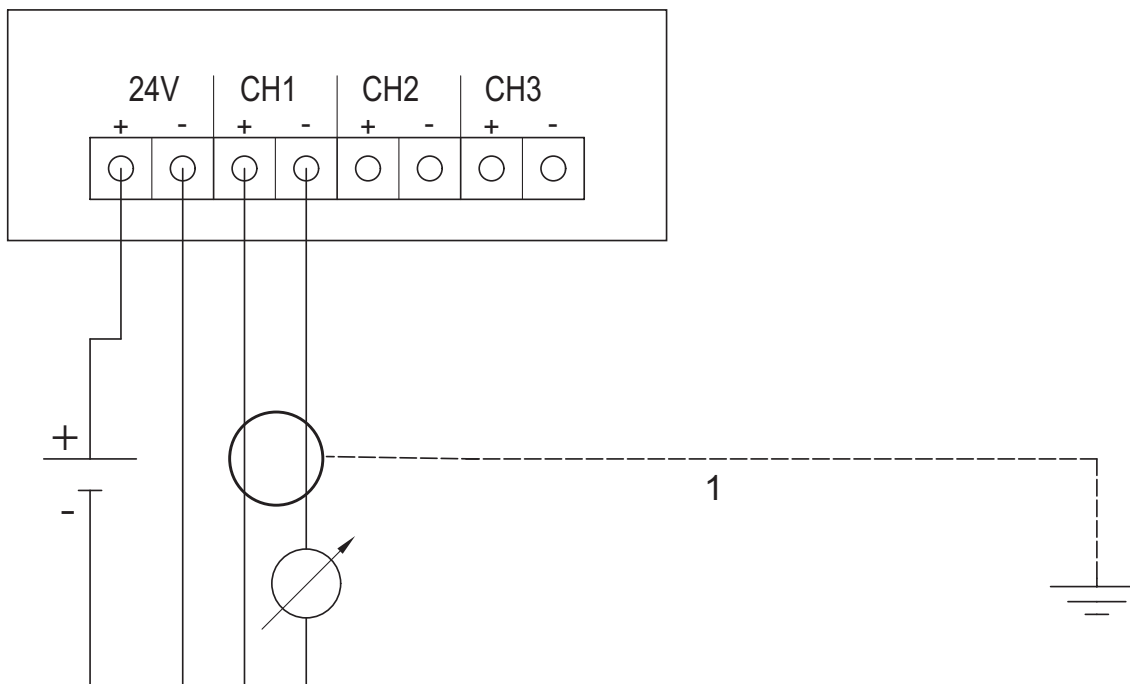



Differential pressure transmitters with high accuracy and long-term stability

Technical data

Parameters		
Differential pressure		
Measuring range	0 to 50 Pa 0 to 100 Pa 0 to 500 Pa 0 to 10 hPa 0 to 50 hPa 0 to 100 hPa 0 to 500 hPa 0 to 1000 hPa 0 to 2000 hPa	-50 to 50 Pa -100 to 100 Pa -500 to 500 Pa -10 to 10 hPa -50 to 50 hPa -100 to 100 hPa -500 to 500 hPa -1000 to 1000 hPa -2000 to 2000 hPa
Measurement uncertainty*	±0.8% of measurement range final value ±0.3 Pa Temperature gain drift: 0.02% of measuring range per Kelvin deviation from nominal temperature 22 °C Zero point drift: 0% (thanks to cyclic zero-point adjustment)	
Selectable units	Differential pressure in Pa, hPa, kPa, mbar, bar, mmH ₂ O, kg/cm ² , PSI, inch HG, inch H ₂ O Calculated variables: Volume flow in m ³ /h, l/min, Nm ³ /h, NI/min Flow velocity in m/s, ft/min	
Sensor	Piezoresistive sensor	
Autom. Zero-point adjustment	via magnetic valve Frequency adjustable: 15 sec, 30 sec, 1 min, 5 min, 10 min	
Overload capacity	Measuring range	Overload
	0 to 50 Pa	20000 Pa
	0 to 100 Pa	20000 Pa
	0 to 500 Pa	20000 Pa
	0 to 10 hPa	200 hPa
	0 to 50 hPa	750 hPa
	0 to 100 hPa	750 hPa
	0 to 500 hPa	2500 hPa
	0 to 1000 hPa	2500 hPa
	0 to 2000 hPa	2500 hPa
	-50 to 50 Pa	20000 Pa
	-100 to 100 Pa	20000 Pa
	-500 to 500 Pa	20000 Pa
	-10 to 10 hPa	200 hPa
	-50 to 50 hPa	750 hPa
	-100 to 100 hPa	750 hPa
	-500 to 500 hPa	2500 hPa
	-1000 to 1000 hPa	2500 hPa
	-2000 to 2000 hPa	2500 hPa

* Measurement inaccuracy according to GUM: ±0.8% of measurement range final value ±0.3 Pa

GUM (Guide to the Expression of Uncertainty in Measurement):

ISO guideline for the determination of measurement inaccuracy, in order to make measurements comparable worldwide.

The following inaccuracies are used for the determination:

- Hysteresis
- Linearity
- Reproducibility
- Long-term stability
- Adjustment site/factory calibration
- Test site

Inputs/outputs	
Analog outputs	
Quantity	1
Output type	0/4 to 20 mA (4-wire) (24 VAC/DC) 0 to 1/5 to 10 V (4-wire) (24 VAC/DC)
Scaling	Differential pressure: scalable ±50% of measuring range final value; freely scalable within measuring range
Meas. cycle	1/sec
Resolution	12 bit
Max. load	max. 500 Ω
Other outputs	
Ethernet	Optional with Ethernet module
Relay	Optional: 4 relays (free allocation to measurement channel or as collective alarm in operating menu/P2A), up to 250 VAC/3A (NO or NC)
Digital	Mini-DIN for P2A software
Supply	
Voltage supply	20 to 30 VAC/DC, 300 mA current consumption, galvanically separate signal and supply line

General technical data		
Model		
Material	Plastic housing	
Dimensions	162 x 122 x 77 mm	
Weight	0.7 kg; optional: Ethernet intermediary layer 0.6 kg	
Display		
Display	Optional: 3-line LCD with multi-language operating menu	
Resolution	Measuring range	Resolution
	0 to 50 Pa	0.1 Pa
	0 to 100 Pa	0.1 Pa
	0 to 500 Pa	0.1 Pa
	0 to 10 hPa	0.01 hPa
	0 to 50 hPa	0.01 hPa
	0 to 100 hPa	0.1 hPa
	0 to 500 hPa	0.1 hPa
	0 to 1000 hPa	1 hPa
	0 to 2000 hPa	1 hPa
	-50 to 50 Pa	0.1 Pa
	-100 to 100 Pa	0.1 Pa
	-500 to 500 Pa	0.1 Pa
	-10 to 10 hPa	0.01 hPa
	-50 to 50 hPa	0.01 hPa
	-100 to 100 hPa	0.1 hPa
	-500 to 500 hPa	0.1 hPa
	-1000 to 1000 hPa	1 hPa
	-2000 to 2000 hPa	1 hPa
Miscellaneous		
Protection class	IP 65	
EMC	EU guideline 2004/108/EC	

Operating conditions	
With / without display	Operating temperature
	-5 to +50 °C / +23 to +122 °F
	Storage temperature
	-20 to +60 °C / -4 to +140 °F
	Process temperature
	-20 to +65 °C / -4 to +149 °F

Differential pressure transmitters with high accuracy and long-term stability



SPECIFICATIONS

testo 6351

The differential pressure transmitter testo 6351 was developed specially for monitoring differential pressure in the measuring range from 50 Pa to 2000 hPa. In cleanroom technology, the maintenance of positive pressure prevents the entry of contaminated air. In order to keep the cleanroom conditions constant, the transmitter additionally calculates the parameters volume flow and flow velocity from the measured differential pressure.

The testo 6351 is particularly outstanding thanks to the automatic zero-point adjustment which ensures high accuracy and long-term stability.

The integrated self-monitoring and early warning function also guarantees the operator high system availability.

Areas of application:

- Differential pressure monitoring between cleanrooms
- Differential pressure monitoring in filling processes
- Monitoring differential pressure, volume flow and flow velocity in critical air conditioning technology (VAC systems)

Subject to change without notice.

Status 12.02.2010

Page 1/4

DS 6351 EN/msp/A/12.02.2010

SPECIFICATIONS
testo 6351

- Measurement of differential pressure, flow velocity and volume flow
- Automatic zero-point adjustment guarantees high, temperature-independent accuracy and long-term stability
- Plastic housing
- Display with multi-language operating menu and optical alarm display
- Ethernet, relay and analog outputs allow optimum integration into individual automation systems
- Self-monitoring of the transmitter and early warning function guarantee high system availability
- The P2A software for parameterization, adjustment and analysis saves time and costs in commissioning and maintenance
- Scalability of ± 50 percent of the measuring range final value and free scalability within the measuring range
- Configurable alarm management with adjustable response delay and alarm acknowledgement