

# Professionals in air flow!

testo 480 VAC analysis measuring instrument



testo 480 offers you:

- > High-quality, digital probes and an intelligent calibration concept
- > Fast and professional reporting PC software
- > Modern trackpad and graphical display



# Perfect climatic conditions with testo 480

For human beings to be comfortable and perform at their best, it is crucial that the rooms they occupy are correctly air conditioned. As well as the structural conditions and personal perception, the following factors also contribute significantly to the existence of a pleasant indoor climate: the indoor air and surface temperature on walls, windows, floors and ceilings, and also the air humidity, movement and quality.

testo 480, the top-quality new measuring instrument for portable climatic measurement technology, facilitates the standards-compliant adjustment of ventilation and air conditioning systems (HVAC systems) in office, residential and industrial buildings and records all relevant parameters when taking climatic measurements.

Because people in particular, not to mention machines and processes, work to 100% efficiency under optimum climatic conditions.

## Cutting-edge technology for professional air conditioning engineers

testo 480 provides integral support to consultants, experts, technical service providers and service technicians in the field of ventilation and air conditioning. Using this one measuring instrument and its probes, you can record parameters such as flow velocity, temperature, humidity, pressure, illuminance, radiated heat, degree of turbulence and CO<sub>2</sub>!



**Advantage:**

Its intelligent calibration and probe concept make the testo 480 impressive. The digital probes with integrated memory notify the instrument once the next calibration is due.

Once the user has entered all calibration data via the software, this is stored in the probe permanently. The probe compensates deviations automatically, thus producing a zero-error display.

Handling all aspects of the calibration process is made easier. The air conditioning engineer can get the probes calibrated without having to send in the hand-held instrument (e.g. at Testo Industrial Services). This means that the measuring instrument can be used with the greatest possible flexibility. In addition, the accuracy of the system, which consists of hand-held instrument and probes, guarantees measuring results that are reliable and reproducible.

# Your pro for indoor climate measurements



## testo 480: simply guides you through the entire measurement chain and the measurement report in just a few steps

From measurement to report, it takes next to no time for the testo 480 to assess the condition of HVAC systems and the comfort level of workplaces:

- Simply input the location straight into the measuring instrument via the large colour display or onto the PC using the “EasyClimate” software.
- Measurement via freely definable measuring programs, e.g. guided HVAC grid measurement according to EN 12599.
- Store readings in the instrument quickly and reliably using the trackpad and assign the location/measuring point.
- Print data on-site, transfer to the PC from SD-card or via USB-cable.
- Analyse, manage and archive the data using the “EasyClimate” PC software. Create reports quickly and easily with the report designer.

Air conditioning engineers have high expectations of their measurement solution. It must be able to offer the utmost assistance in undertaking a large number of measuring tasks, reliably and without error. These tasks include the standards-compliant adjustment of HVAC systems, providing customers with great potential for cost- and energy-saving. At the same time testo 480 helps to stem the growing air conditioning and ventilation energy costs, and to reduce unnecessary energy consumption.

### **Advantage:**

testo 480 guides users through the entire measurement chain in a way that enables them to save both time and money.

This measuring instrument bolsters the user’s skills and is impressive with its modern design and cutting-edge technology Made in Germany. As a long-standing partner of air conditioning professionals the world over, Testo AG is well aware of their needs and the challenges they face. This knowledge has been put into practice in the testo 480.

We measure it.



# Perfectly equipped for every challenge



## Duct measurement

The flow probes are used for measuring in ducts in order to check the adjustment of the HVAC system and correct it if necessary. They come with a robust non-rotatable telescope and are therefore also suitable for measuring in large air ducts or in places that are difficult to access. The scaling on the telescopes means that the immersion depth can be read off easily for a HVAC grid measurement, and implemented by the integrated measuring program in compliance with the standards.

### Advantage:

testo 480 saves time and provides reliability for HVAC measurement. You can be sure that the ventilation system will be adjusted correctly and will be energy-efficient at all times. This eliminates the need for complex recalculations and the resultant additional processing steps. Air conditioning engineers can use testo 480 to carry out reliable measurements in shorter time for more customers.



## Air outlets

testo 480 checks whether a system's air distribution is optimally balanced. Because a volume flow at the outlet that is either too low or too high has a direct impact on a person's comfort (e.g. due to a draught) or the system's energy consumption.

### Advantage:

testo 480 carries out measurements at many different outlets in a manner that is simple and adaptable. Depending on the size and type of outlet, assorted volume flow funnels are available which can be used to reliably measure the air volume.

## Comfort level and indoor air quality

The testo 480's intelligent probes record all climatic values acting upon human beings in the workplace. A special comfort level tripod safely incorporates globe probe, degree of turbulence probe, humidity probe and hand-held instrument, and facilitates convenient measurement on-site according to the standards.

### Advantage:

testo 480 instantly detects the causes of negative environmental influences, e.g. draught, and reliably assists the user with solving problems. Employee performance increases when there is a pleasant indoor climate in the workplace and energy costs are sustainably reduced.





## Probes for duct measurement

### **16 mm vane probe** (0635 9542):

including telescope with easy-to-read scaling and integrated measurement button

### **Thermal probe** (0635 1543):

90° bendable including telescope with easy-to-read scaling and integrated measurement button

## Probes for air outlet measurement

### **100 mm vane probe** (0635 9343):

Can be used with funnel set and in combination with separately available extension

## Probes for comfort level and indoor air quality

### **IAQ probe** (0632 1543):

In one step: CO<sub>2</sub>, temperature, humidity and absolute pressure including desk-top stand

### **Globe probe** (0602 0743):

Measures radiated heat with thermocouple probe type K, class 1

### **Comfort level probe** (0628 0143):

Standards-compliant measurement according to EN 13779

### **Lux probe** (0635 0543):

Assesses lighting conditions in workplaces

### **Humidity probe** (0636 9743):

High-precision 1% humidity probe

### **Pt100** (0614 0073):

High-precision immersion and penetration probe

# “EasyClimate”: Climate data management is now very easy!

## Probes



The measuring instrument comes with the new “EasyClimate” PC software. This software will make data evaluation even easier. Its modern user interface guarantees clarity and intuitive operation. Measurement reports can be configured easily and personalised to customer requirements using the specially devised report designer. Customer data, locations and measuring results can be edited in tabular or graphic format and saved with just a few clicks of the mouse.

All information is deposited centrally and can be called up at any time. With testo 480 data transfer is simple and convenient, and no time is wasted.

## Technical data

Probe connections	2 x TC Type K, 1 x differential pressure, 3 x digital
Other connections	USB interface, SD-Card, mains unit, infrared for fast printer
Operating temperature	0 to 40°C
External power supply	External power supply via connected mains unit for long-term measurements and battery charging
Battery life	approx. 17 hours (hand-held instrument without probe with 50% display brightness)
Display	Colour graphics display
Memory	1.8 GB (approx. 60,000,000 measurement values)

Integrated measurement	Measurement range	Resolution
Probe TC Type K	-200 to +1370 °C	0.1 °C
Differential pressure	-25 to 25 hPa	0.001 hPa
Absolute pressure	700 to 1100 hPa	0.1 hPa

Integrated measurement	Accuracy (± 1 digit)
Probe TC Type K	±(0.3°C + 0,1% of m.v.)
Differential pressure	±(0.3 Pa + 1% of m.v.)
Absolute pressure	±3 hPa









## Ordering suggestions

Comfort level measurement	Order No.
testo 480 including "EasyClimate" PC software, mains unit, USB-cable and calibration protocol	0563 4800
Tripod for comfort level measurement	0554 0743
Degree of turbulence probe*	0628 0143
Globe probe, Ø 150 mm	0602 0743
Humidity and temperature probe, Ø 12 mm*	0636 9743
IAQ probe including desk-top stand*	0632 1543
Lux probe	0635 0543
System case for comfort level measurements	0516 4801
*Plug-in head cable (mandatory)	0430 0100





HVAC measurement	Order No.
testo 480 including "EasyClimate" PC software, mains unit, USB-cable and calibration protocol	0563 4800
Vane probe, Ø 16 mm with telescope*	0635 9542
Thermal flow probe with telescope*	0635 1543
Vane probe, Ø 100 mm*	0635 9343
Humidity and temperature probe, Ø 12 mm*	0636 9743
IAQ probe including desk-top stand*	0632 1543
Prandtl pitot tube 350 mm	0635 2145
System case for HVAC measurements	0516 4800
*Plug-in head cable (mandatory)	0430 0100

# A pro for all eventualities: Your equipment for testo 480

## Probes

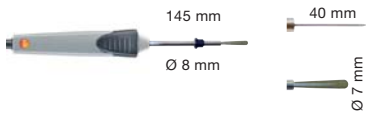
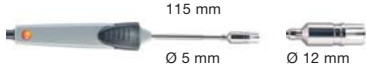



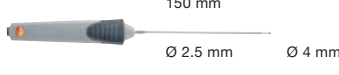
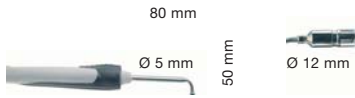

Flow probes		Measurement range	Accuracy ( $\pm 1$ digit)	Order No.
Vane probe, $\varnothing$ 16 mm, including non-rotatable telescope with scaling to max. 960 mm, with integrated measurement button, e.g. for velocity measurements in ducts *		+0.4 to +50 m/s -10 to +70 °C	$\pm(0.2 \text{ m/s} + 1\% \text{ of reading})$ 0.4 - 40 m/s $\pm(0.2 \text{ m/s} + 2\% \text{ of reading})$ 40 - 50 m/s $\pm 1.8 \text{ }^\circ\text{C}$	0635 9542
Thermal probe, $\varnothing$ 10 mm, 90° bendable (200 mm), including non-rotatable telescope with scaling to max. 1100 mm, integrated measurement button, e.g. for velocity measurements in ducts *		0 to +20 m/s -20 to +70 °C 0 to 100 %RH +700 to +1100 hPa	$\pm(0.03 \text{ m/s} + 4\% \text{ of reading})$ $\pm 0.5 \text{ }^\circ\text{C}$ $\pm(1.8 \text{ \%RH} + 0.7\% \text{ of reading})$ $\pm 3 \text{ hPa}$	0635 1543
Vane probe $\varnothing$ 100 mm, for measurements at duct outlet *		0.10 to +15.00 m/s 0 to +60 °C	$\pm(0.1 \text{ m/s} + 1.5\% \text{ of reading})$ $\pm 0.5 \text{ }^\circ\text{C}$	0635 9343
<b>Comfort level probes</b>				
Humidity and temperature probe $\varnothing$ 12 mm, high-precision with 1% accuracy *		0 to 100 %RH -20 to +70 °C	$\pm(1.0 \text{ \%RH} + 0.7\% \text{ of reading})$ 0 to 90 %RH $\pm(1.4 \text{ \%RH} + 0.7\% \text{ of reading})$ 90 to 100 %RH $\pm 0.5 \text{ }^\circ\text{C}$	0636 9743
IAQ probe to assess Indoor Air Quality, CO <sub>2</sub> , humidity, temperature and absolute pressure measurement, including desk-top stand *		0 to +50 °C 0 to +100 RH 0 to 10,000 ppm CO <sub>2</sub>  +700 to +1100 hPa	$\pm 0.5 \text{ }^\circ\text{C}$ $\pm (1.8 \text{ \%RH} + 0.7\% \text{ of reading})$ $\pm (50 \text{ ppm CO}_2 + 2\% \text{ of reading})$ 0 to +5,000 ppm CO <sub>2</sub> $\pm (100 \text{ ppm CO}_2 + 3\% \text{ of reading})$ 5.001 to +10,000 ppm CO <sub>2</sub> $\pm 3 \text{ hPa}$	0632 1543
Comfort probe for degree of turbulence measurement, standards-compliant measurement according to EN 13779 *		0 to +50 °C 0 to +5 m/s +700 to +1100 hPa	$\pm 0.5 \text{ }^\circ\text{C}$ $\pm(0.03 \text{ m/s} + 4\% \text{ of reading})$ $\pm 3 \text{ hPa}$	0628 0143
Globe thermometer $\varnothing$ 150mm, measures radiated heat		0 to +120 °C	Type K thermocouple, class 1	0602 0743
Lux probe, for measuring light intensity		0 to 100,000 Lux	Class C according to DIN 5032-7 f1 = 6% V-Lambda f2 = 5% cos	0635 0543
<b>Further probes</b>				
High-precision Pt100 immersion and penetration probe *	200 mm  $\varnothing$ 3 mm	-100 ... +400 °C	$\pm 0.15 \text{ }^\circ\text{C} + 0.2\% \text{ of reading}$ (-100 ... -0.01 °C) $\pm 0.15 \text{ }^\circ\text{C} + 0.05\% \text{ of reading}$ (0 ... 100 °C) $\pm 0.15 \text{ }^\circ\text{C} + 0.2\% \text{ of reading}$ (100.01 ... -350 °C) $\pm 0.5 \text{ }^\circ\text{C} + 0.5\% \text{ of reading}$ (350.01 ... 400 °C)	0614 0073
*Plug-in head cable (mandatory)				0430 0100

## Probes

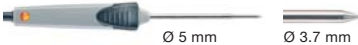
Thermocouple probes	Dimensions Probe shaft/probe shaft tip	Measuring range	Accuracy	t <sub>99</sub>	Order No.
Spare meas. head for pipe wrap probe, TC Type K		-60 to +130 °C	Class 2	5 sec	0602 0092
Fast-reaction paddle surface probe, for measurements in inaccessible places, e.g. narrow apertures and slots, TC Type K, Fixed cable		0 to +300 °C	Class 2 <sup>1)</sup>	5 s	0602 0193
Fast-action surface probe with sprung thermocouple strip, also for uneven surfaces, measurement range short-term to +500°C, TC Type K, Fixed cable		-60 to +300 °C	Class 2 <sup>1)</sup>	3 s	0602 0393
Efficient and fast-action immersion probe, waterproof, TC Type K, Fixed cable		-60 to +1000 °C	Class 1 <sup>1)</sup>	2 s	0602 0593
Thermocouple with TC adapter, flexible, 800mm long, fibre glass, TC Type K		-50 to +400 °C	Class 2 <sup>2)</sup>	5 s	0602 0644
Thermocouple with TC adapter, flexible, 1500mm long, fibre glass, TC Type K		-50 to +400 °C	Class 2 <sup>2)</sup>	5 s	0602 0645
Thermocouple with TC adapter, flexible, 1500mm long, PTFE, TC Type K		-50 to +250 °C	Class 2 <sup>2)</sup>	5 s	0602 0646
Efficient, waterproof surface probe with small measurement head for flat surfaces, TC Type K, Fixed cable		-60 to +1000 °C	Class 1 <sup>2)</sup>	20 s	0602 0693
Fast-action surface probe with sprung thermocouple strip, bent, also for uneven surfaces, measurement range short-term to +500°C, TC Type K, Fixed cable		-60 to +300 °C	Class 2 <sup>2)</sup>	3 s	0602 0993

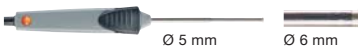
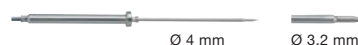

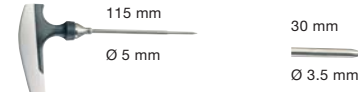
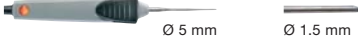

1) According to standard EN 60584-2, the accuracy of Class 1 refers to -40 to +1000 °C (Type K), Class 2 to -40 to +1200 °C (Type K), Class 3 to -200 to +40 °C (Type K).

## Probes

Thermocouple probes	Dimensions Probe shaft/probe shaft tip	Measuring range	Accuracy	t <sub>99</sub>	Order No.
Waterproof immersion/penetration probe, TC Type K, Fixed cable	 114 mm Ø 5 mm      50 mm Ø 3.7 mm	-60 to +400 °C	Class 2 <sup>1)</sup>	7 s	0602 1293
Robust, waterproof surface temperature probe, Pt100, Fixed cable	 114 mm	-50 to +400 °C	Class B <sup>1)</sup>	40 s	0609 1973
Waterproof surface probe with widened measurement tip for flat surfaces, T/C Type K, Fixed cable	 115 mm Ø 5 mm      Ø 6 mm	-60 to +400 °C	Class 2 <sup>1)</sup>	30 s	0602 1993
Waterproof food probe made of stainless steel (IP65), TC Type K, Fixed cable	 125 mm      30 mm Ø 4 mm      Ø 3.2 mm	-60 to +400 °C	Class 2 <sup>1)</sup>	7 s	0602 2292
Flat head surface probe with telescopic handle max. 680 mm for measurements at hard-to-access points, TC Type K, Fixed cable 1.6 m (correspondingly shorter when telescope extended)	 680 mm      12 mm Ø 25 mm	-50 to +250 °C	Class 2 <sup>1)</sup>	3 s	0602 2394
Robust food probe with special handle, IP 65, reinforced cable (PUR), T/C Type K, Fixed cable	 115 mm Ø 5 mm      30 mm Ø 3.5 mm	-60 to +400 °C	Class 1 <sup>1)</sup>	6 s	0602 2492
Fast-action, waterproof immersion/penetration probe, TC Type K, Fixed cable	 60 mm      14 mm Ø 5 mm      Ø 1.5 mm	-60 to +800 °C	Class 1 <sup>1)</sup>	3 s	0602 2693
Pipe wrap probe for pipe diameter 5 to 65 mm, with exchangeable measuring head. Meas. range short-term to +280°C, TC Type K, Fixed cable		-60 to +130 °C	Class 2 <sup>1)</sup>	5 s	0602 4592
Clamp probe for measurements on pipes, pipe diameter 15 to 25 mm (max. 1"), meas. range short-term up to +130°C, TC Type K, Fixed cable		-50 to +100 °C	Class 2 <sup>1)</sup>	5 s	0602 4692

1) According to standard EN 60584-2, the accuracy of Class 1 refers to -40 to +1000 °C (Type K), Class 2 to -40 to +1200 °C (Type K), Class 3 to -200 to +40 °C (Type K).

## Probes

Thermocouple probes	Dimensions Probe shaft/probe shaft tip	Measuring range	Accuracy	t <sub>99</sub>	Order No.
Magnetic probe, adhesive force approx. 20 N, with magnets, for measurements on metal surfaces, TC Type K, Fixed cable		-50 to +170 °C	Class 2 <sup>1)</sup>	150 s	0602 4792
Magnetic probe, adhesive force approx. 10 N, with magnets, for higher temp., for measurements on metal surfaces, TC Type K, Fixed cable		-50 to +400 °C	Class 2 <sup>1)</sup>		0602 4892
Immersion tip, flexible, TC Type K		-200 to +1000 °C	Class 1 <sup>1)</sup>	5 s	0602 5792
Immersion tip, flexible, TC Type K		-200 to +40 °C	Class 3 <sup>1)</sup>	5 s	0602 5793
Immersion measurement tip, flexible, for measurements in air/exhaust gases (not suitable for measurements in smelters), TC Type K		-200 to +1300 °C	Class 1 <sup>1)</sup>	4 s	0602 5693

1) According to standard EN 60584-2, the accuracy of Class 1 refers to -40 to +1000 °C (Type K), Class 2 to -40 to +1200 °C (Type K), Class 3 to -200 to +40 °C (Type K).

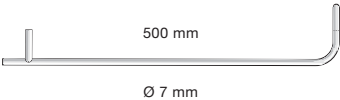
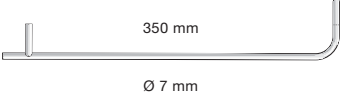
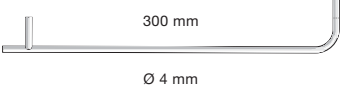
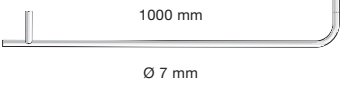
Prandtl's Pitot tubes	Dimensions Probe shaft/probe shaft tip	Order No.
Pitot tube, 500 mm long, Ø 7 mm, stainless steel, for measuring flow velocity		Oper. temp. 0 to +600 °C  0635 2045
Pitot tube, 350 mm long, Ø 7 mm, stainless steel, for measuring flow velocity		Oper. temp. 0 to +600 °C  0635 2145
Pitot tube, 300 mm long, Ø 4 mm, stainless steel, for measuring flow velocity		Oper. temp. 0 to +600 °C  0635 2245
Pitot tube, 1000 mm long, Ø 7 mm, stainless steel, for measuring flow velocity		Oper. temp. 0 to +600 °C  0635 2345

## Accessories

Accessories for measuring instrument and probes	Details	Order No.
Tripod for workplace evaluation	With holders for hand-held instrument and probes. Can also be used as probe extension.	0554 0743
Plug-in head cable	Connection of digital probes to the measuring instrument	0430 0100
Testovent 410 volume flow funnel	Ø 340 mm/330 x 330 mm, including carrying bag	0554 0410
Testovent 415 volume flow funnel	Ø 210 mm/190 x 190 mm, including carrying bag	0554 0415
Funnel set for disc valves and ventilators	Disc valves (Ø 200) ventilators (330 x 330 mm) for incoming and outgoing air	0563 4170
Testo saline pots	Humidity adjustment 11.3%RH and 75.3%RH including adapter for humidity probe	0554 0660
Connection hose	Connection hose silicone 5 m to max. 700 hPa	0554 0440
Connection hose silicone-free	Connection hose silicone-free 5 m to max. 700 hPa	0554 0453

System case	Details	Order No.
System case for comfort level measurements	For instrument, probes and other accessories; incl. globe thermometer and degree of turbulence probe	0516 4801
System case for HVAC measurements	For instrument, probes and other accessories; incl. 16 mm vane probe and thermal flow velocity probe	0516 4800

Printers and accessories	Details	Order No.
Testo fast printer	Infrared interface, 1 roll of thermal paper and 4 AA batteries	0554 0549
Spare thermal paper for printer (6 rolls)	Measurement data documentation legible for up to 10 years	0554 0568



System case for HVAC measurements



System case for comfort level measurements



## Accessories

Calibration Certificates	Order No.
ISO calibration certificate/temperature for air/immersion probes, calibration points -18°C; 0°C; +60°C	0520 0001
DAkkS calibration certificate/temperature meas. instr. with air/immersion probe; calibration points -20 °C; 0 °C; +60 °C	0520 0211
ISO calibration certificate humidity Calibration points 11.3 %RH and 75.3 %RH at +25°C	0520 0006
DAkkScalibration certificate humidity Electronic hygrometer; calibration points 11.3 %RH and 75.3 %RH at +25 °C	0520 0206
ISO calibration certificate pressure differential pressure, accuracy 0.1 to 0.6 (% of fsv)	0520 0025
ISO calibration certificate velocity hot wire, vane anemometer, Pitot tube; calibration points 1; 2; 5; 10 m/s	0520 0004
ISO calibration certificate velocity hot wire, vane anemometer, Pitot tube; calibration points 5; 10; 15; 20 m/s	0520 0034
ISO calibration certificate/light Calibration points 0; 500; 1000; 2000; 4000 Lux	0520 0010
ISO calibration certificate/CO2 CO2 probes; calibration points 0; 1000; 5000 ppm	0520 0033
More calibration certificates on request	

